

Cross Layer Protocol Design

Radio Communication III



»»» mobile phones

The layered world of protocols

Video Compression for Mobile Communication



Overview

- » Image formats
- » Pixel representation
- » Still image compression
- » Video compression using temporal prediction
- » Video measurements

Image Formats

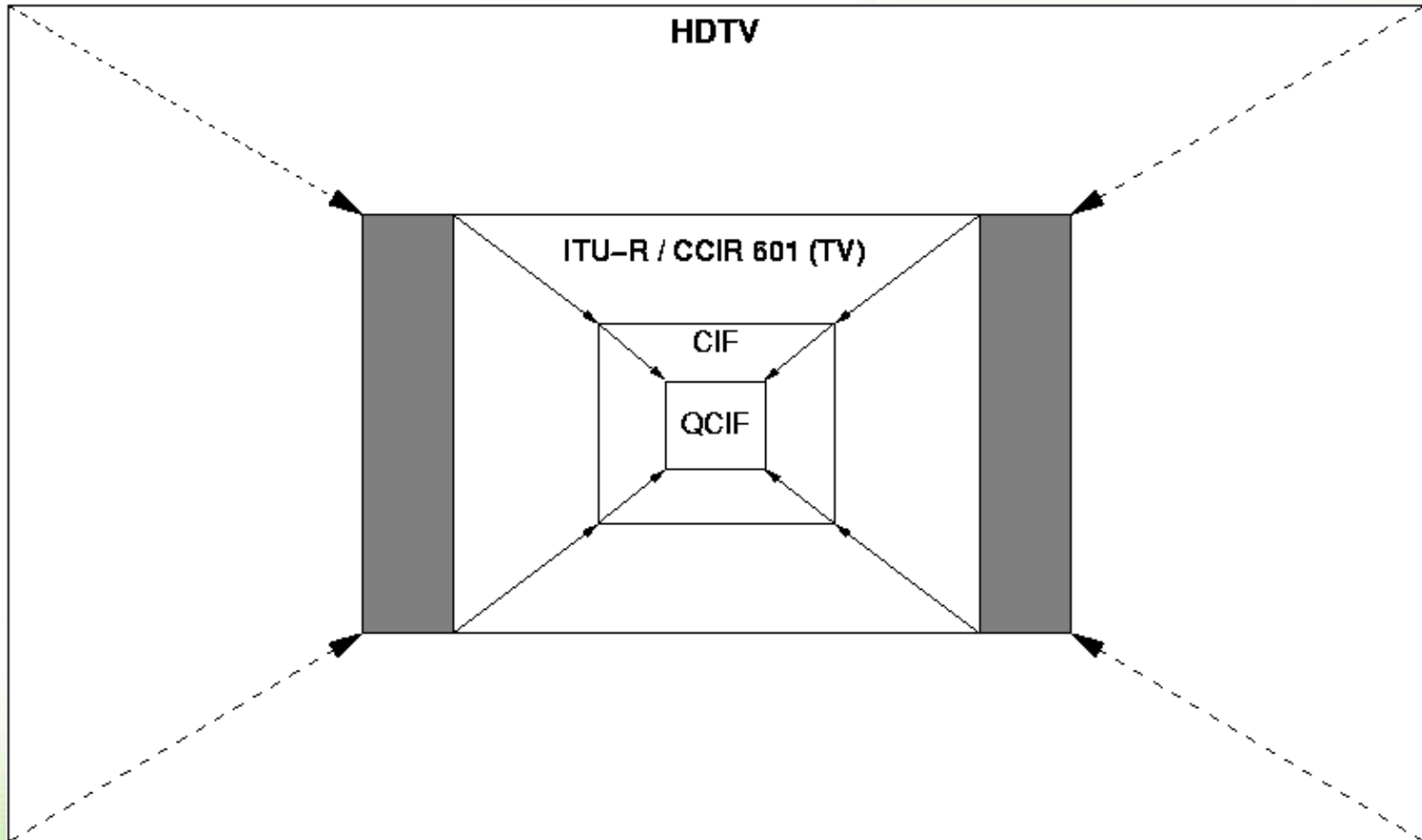

Pixel Representation

- » A pixel can be described by three color elements RED, GREEN, and BLUE
- » YUV is another possibility of representation
 - Y luminance
 - U chrominance
 - V saturation
- » Human eye is more sensitive to the Y component

Pixel Representation

- » To reduce the data rate the YUV sub sampling can be used
- » 4:4:4 -> 4:1:1 -> 4:2:0
- » YUV for B&W TV

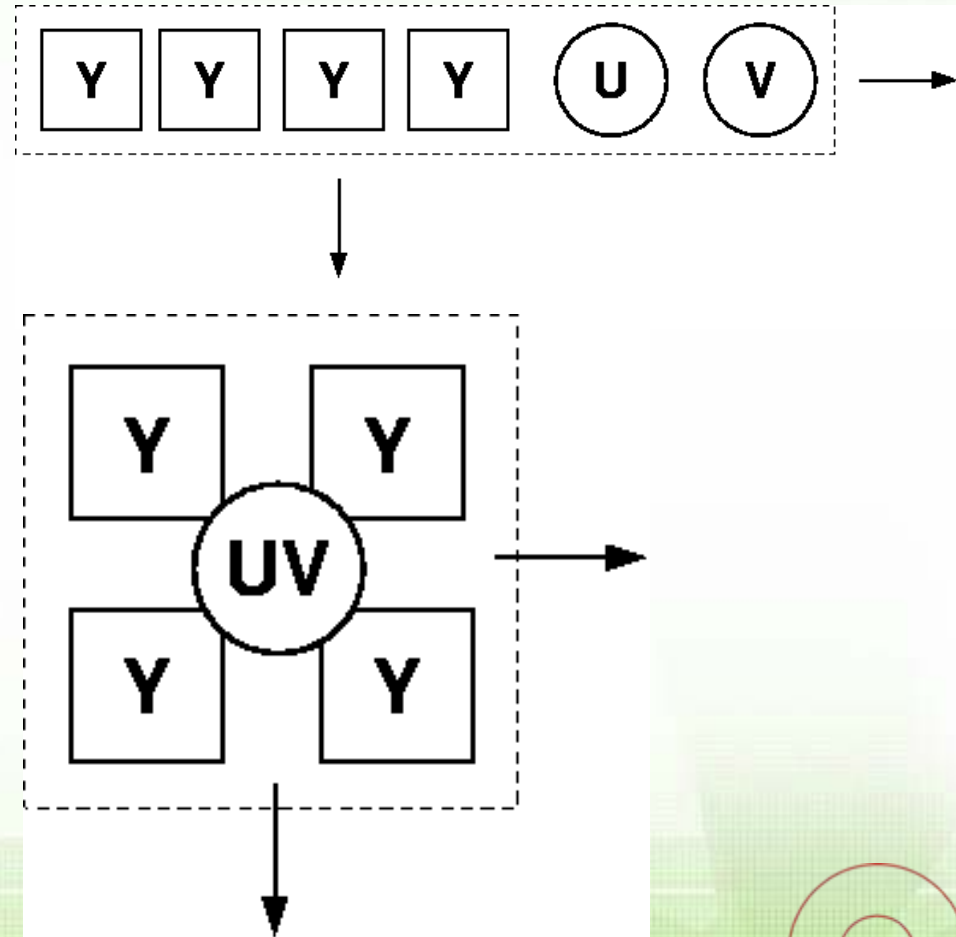

Image Format and Related Data Rates

	QCIF	CIF/SIF	ITU-R 601	HDTV
Pixels/line (Y)	176	352	720	1920
Number of lines (Y)	144	288 (240)	576 (480)	1080
Pixels/line(U,V)	88	176	360	960
Number of lines (U,V)	72	144 (120)	576 (480)	1080
Frame rate [Hz]	10	30	25 (30)	25 (30)
Data rate [Mbit/s]	3,04	36,5 (30,4)	165,9	884,7

»»» mobile phones

Introduction Compression Ratio and Mobile Channels

Compression Ratio and
Data Rates

Capacity of Mobile
Channels
(estimates)

HDTV with CG= 30 ->

30Mbit/s

TV (ITU-R 601)

GSM: 9.6 kbit/s

GPRS: 30kbit/s

EDGE: 80 kbit/s

UMTS: 300 kbit/s

DAB: 1.5 Mbit/s

DVB-T: 24 Mbit/S

Signal Compression Task

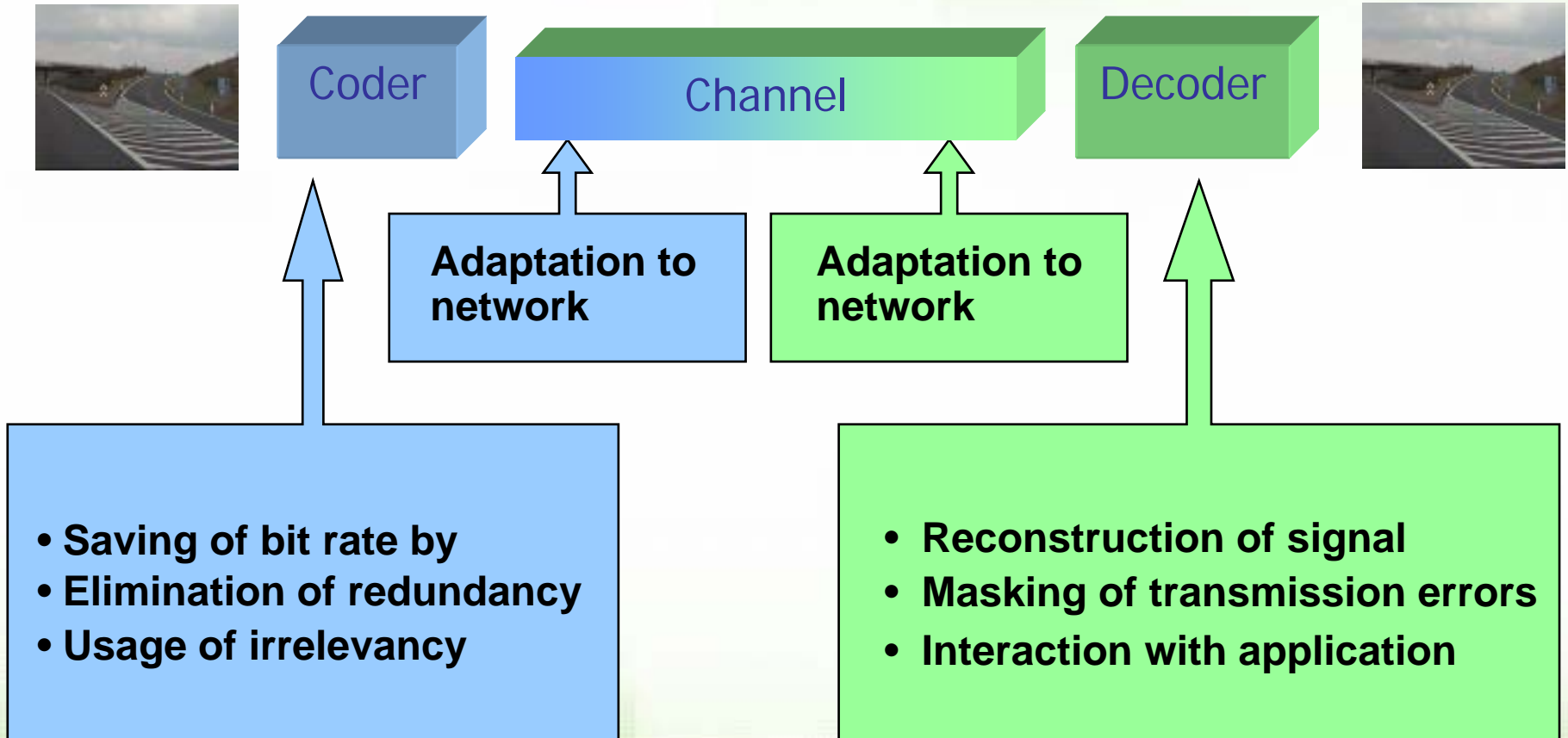

Composition of a Video Sequence

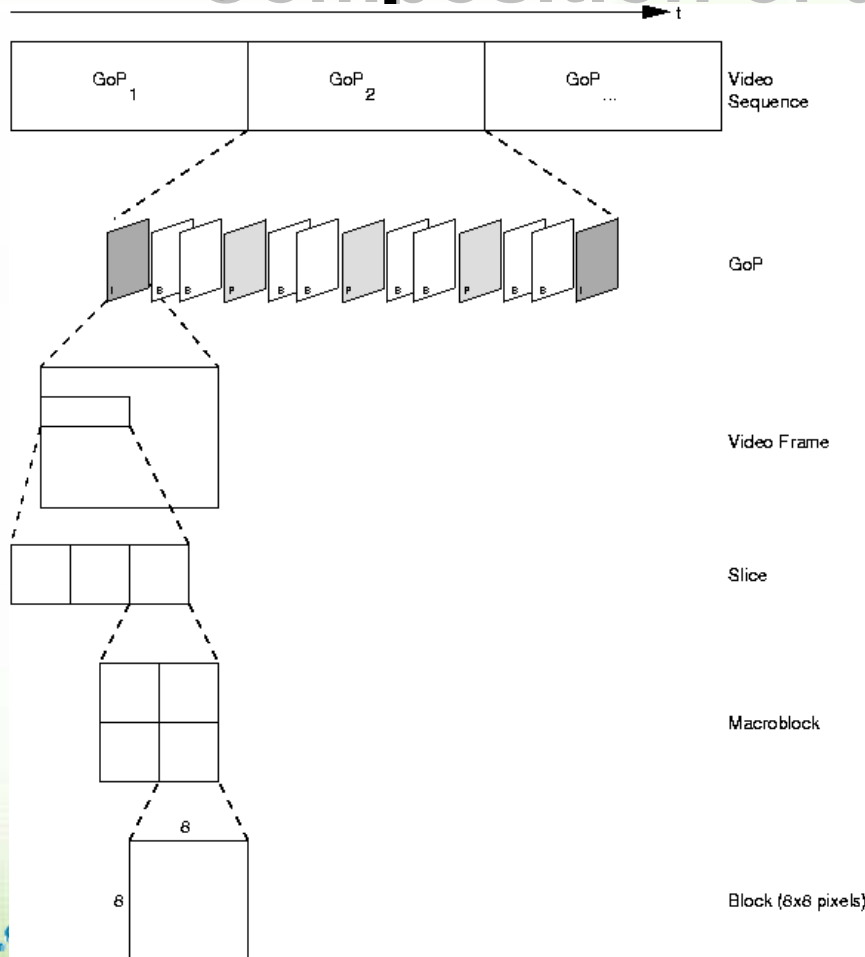

- Video Sequence
- Gop
- Video Frame
- Slice
- Macroblock
- Block (8x8)

Block Scanning

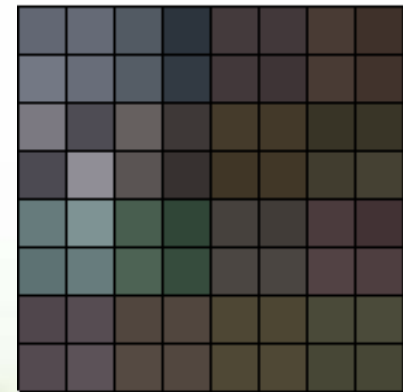
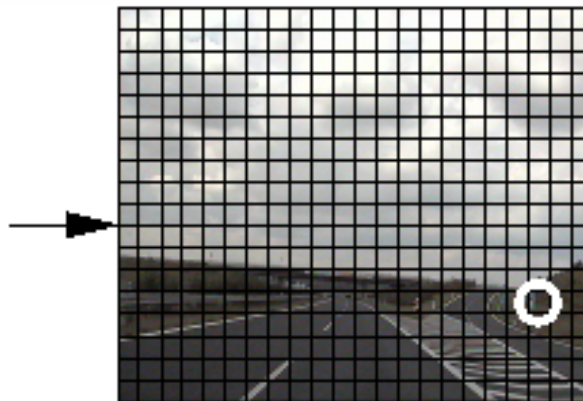
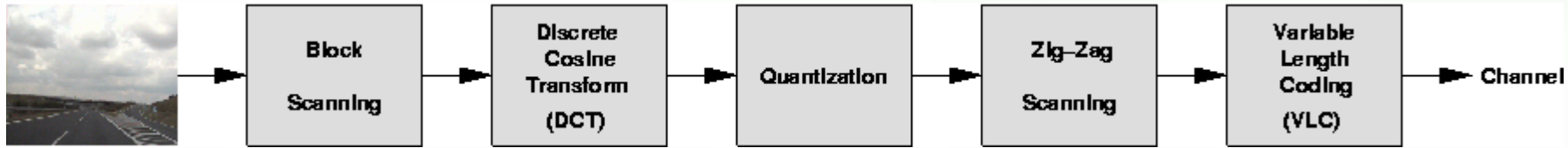

Discrete Cosinus Transformation

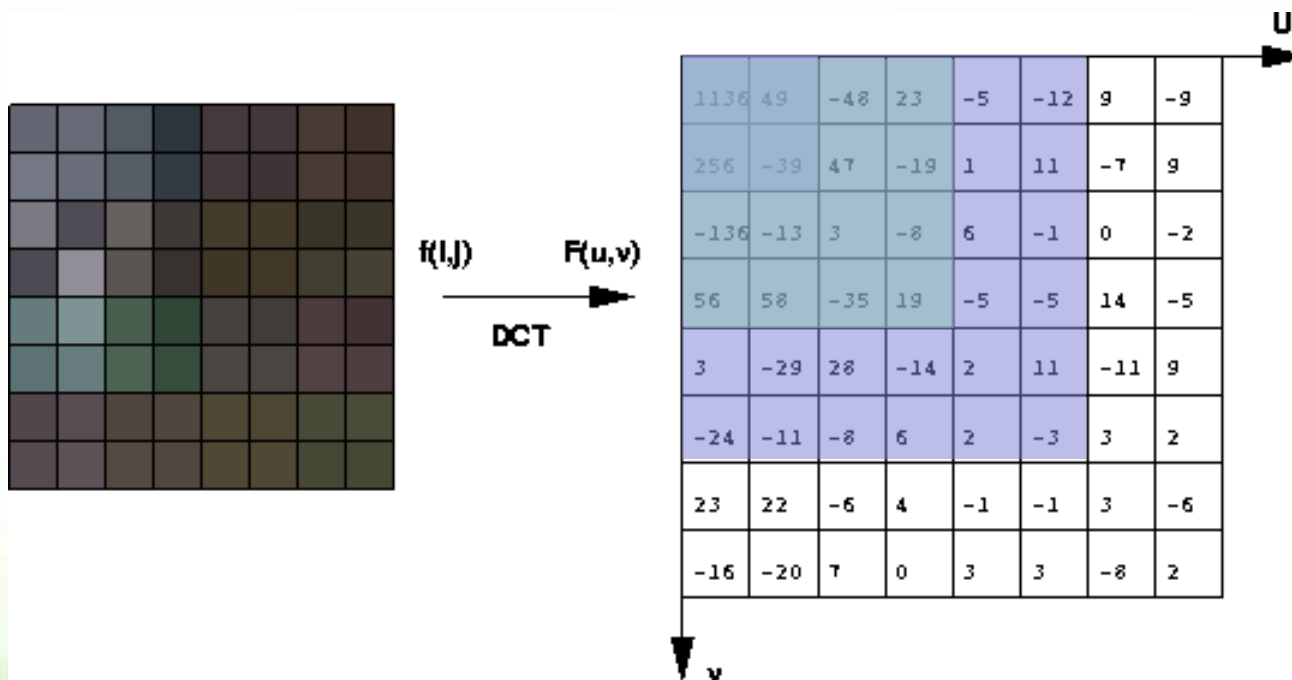
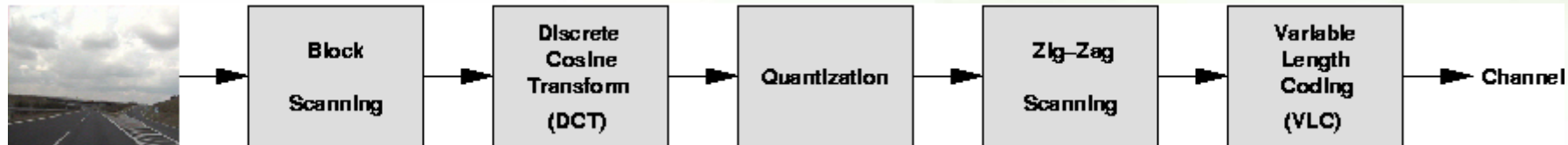

Quantization

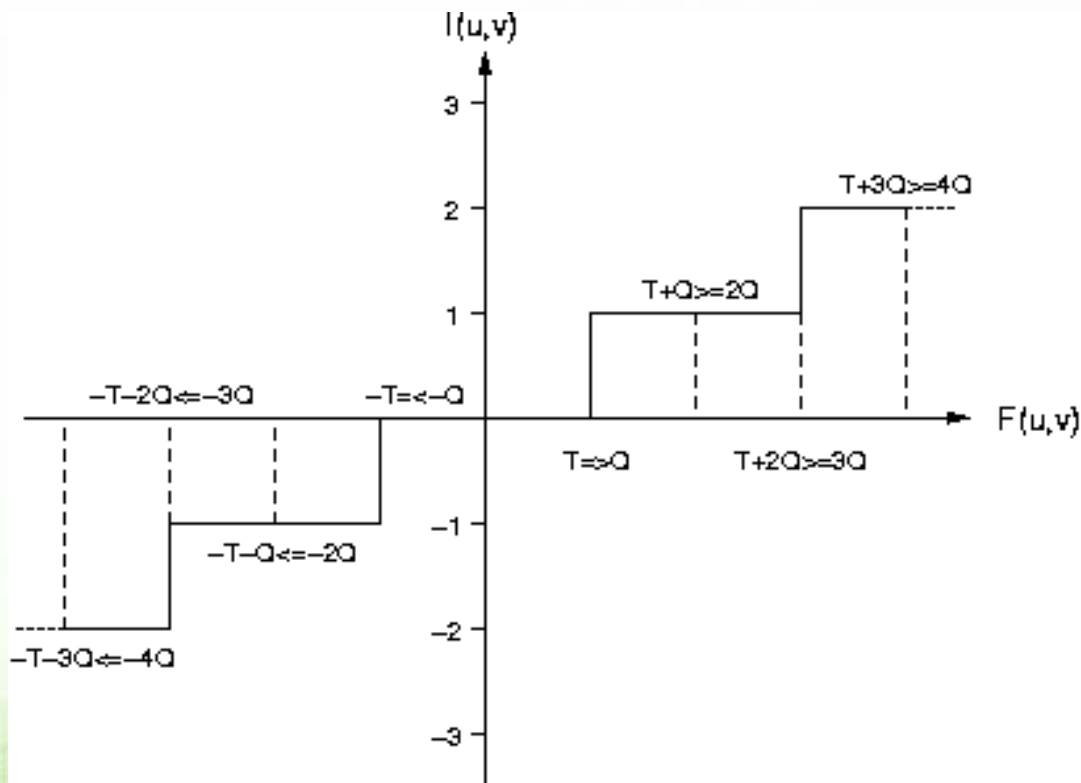
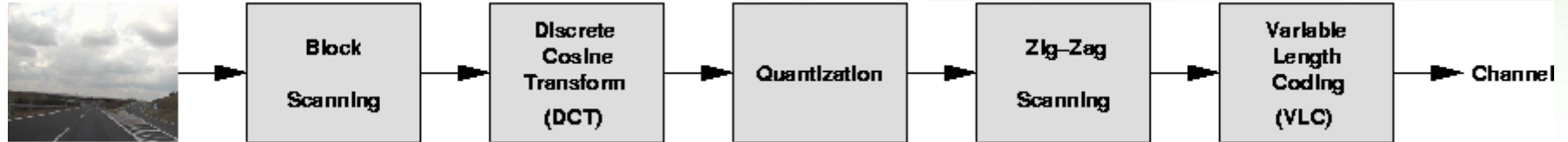

Quantization

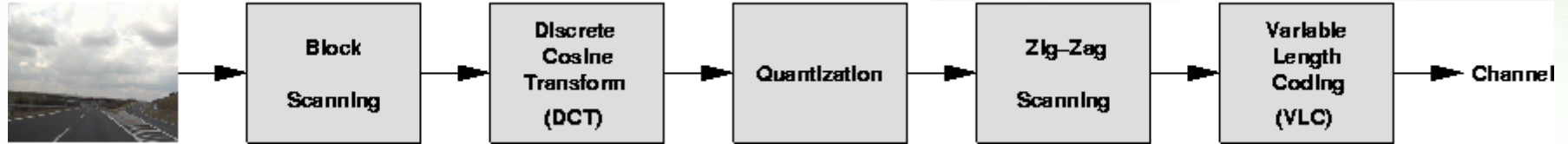

Q=16

PSNR 44.9579

4640 byte

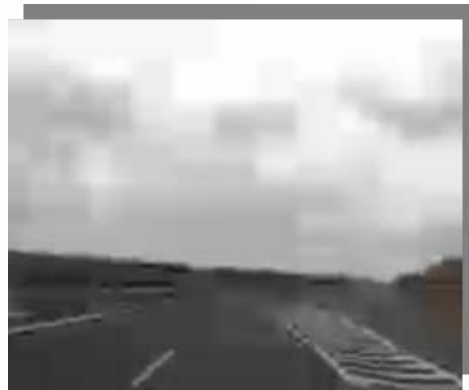

Q=35

PSNR 33.0344

135 byte



Q=40

PSNR 30.2765

79 byte

Zig-Zag Scanning and Variable Length Coding (VLC)

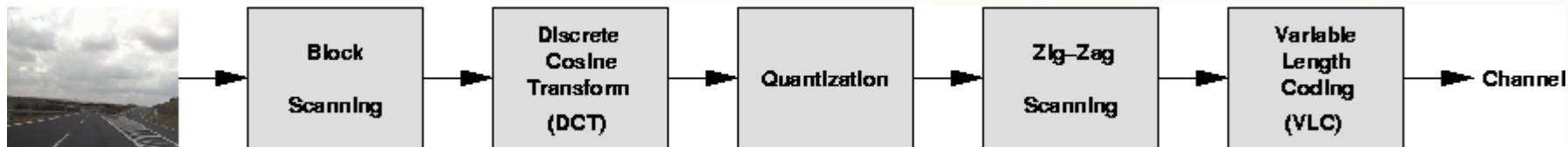

36	2	-2	1	0	0	0	0
8	-1	1	-1	0	0	0	0
-4	0	0	0	0	0	0	0
2	2	-1	1	0	0	0	0
0	-1	1	0	0	0	0	0
-1	0	0	0	0	0	0	0
1	1	0	0	0	0	0	0
-1	-1	0	0	0	0	0	0

36	2	-2	1	0	0	0	0
8	-1	1	-1	0	0	0	0
-4	0	0	0	0	0	0	0
2	2	-1	1	0	0	0	0
0	-1	1	0	0	0	0	0
-1	0	0	0	0	0	0	0
1	1	0	0	0	0	0	0
-1	-1	0	0	0	0	0	0

36, 2, 8, -4, -1...

Concept of DCT coding (JPEG, MPEG, H.26x)

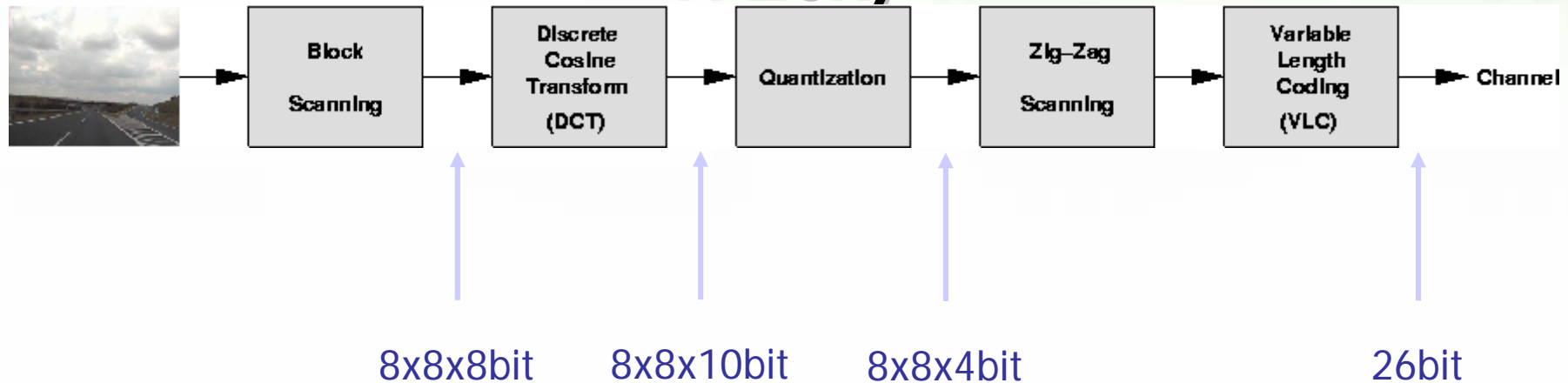

Compression Gain 20

- Example: 8 bit color depth; 10 bit DCT coefficient; 4 bit quantization
- Amount of data might increase after DCT
- Main compression is achieved with ZZ scanning and VLC
- Compression of 20 is not enough for mobile channels

Compression with temporal prediction

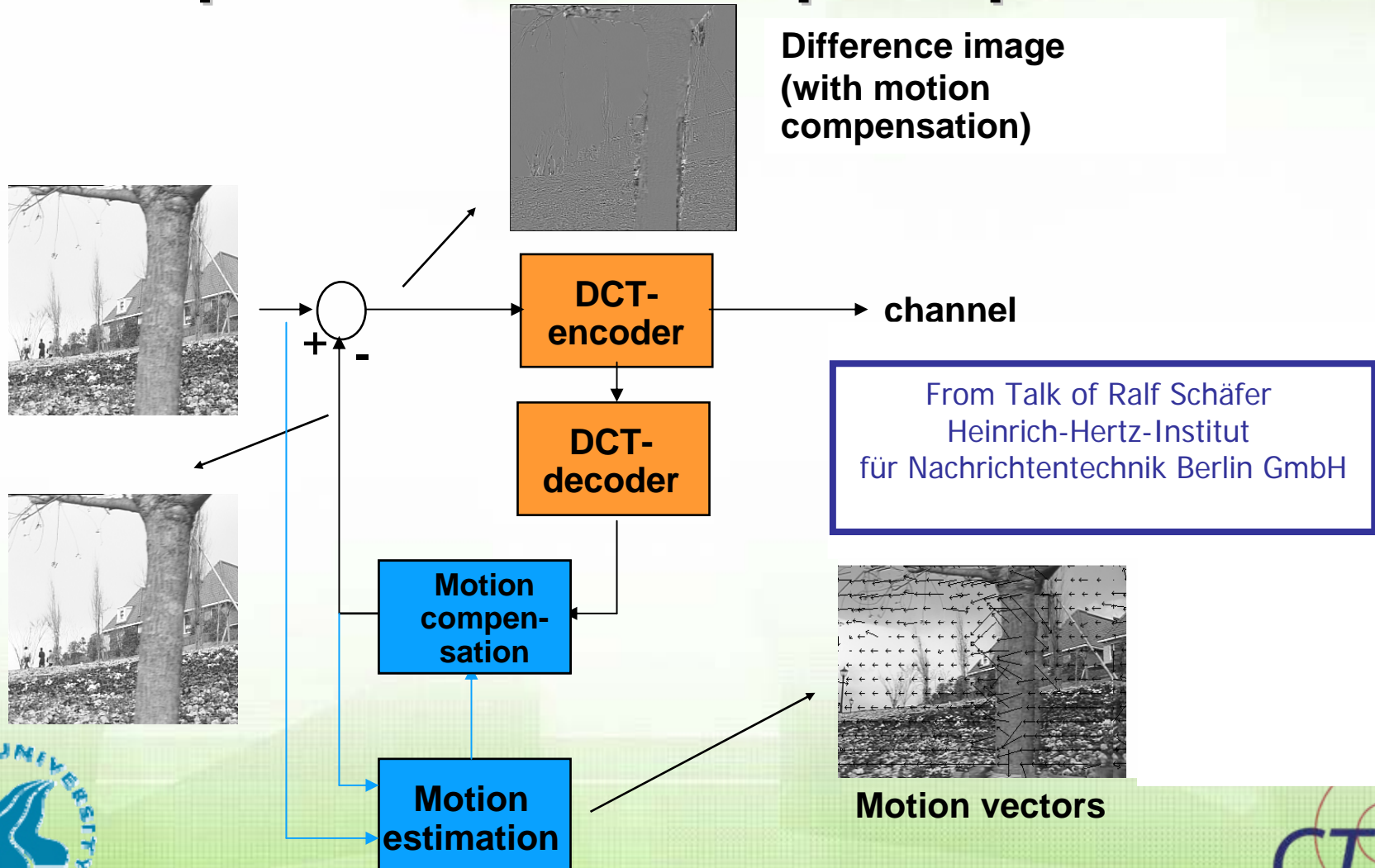

Motion Compensation

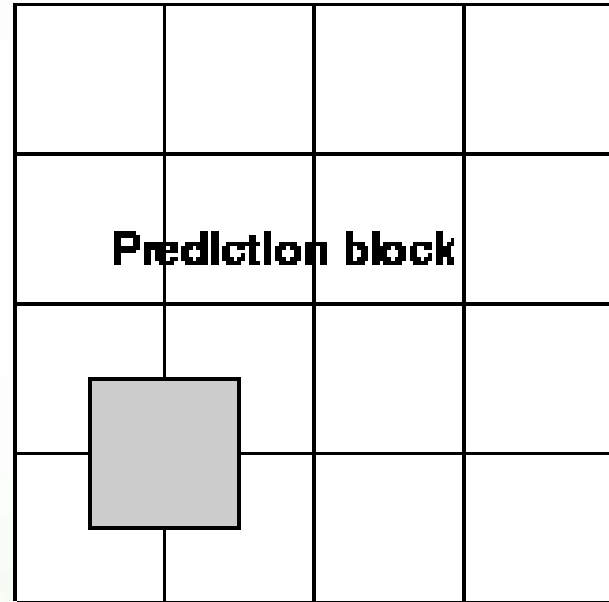
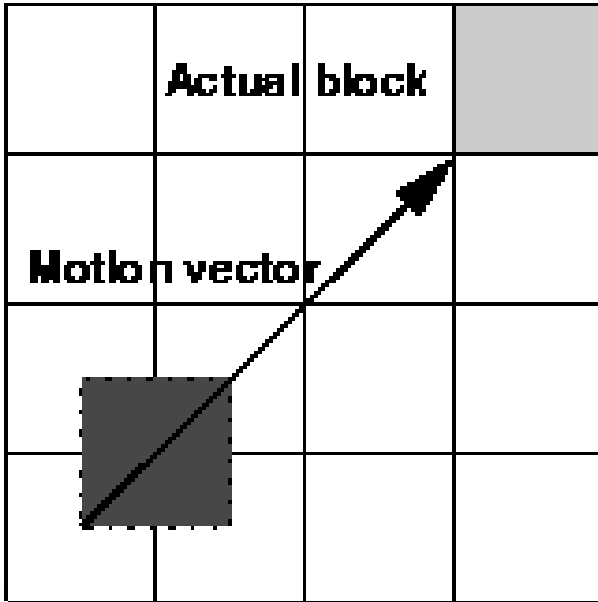

Where are the information?

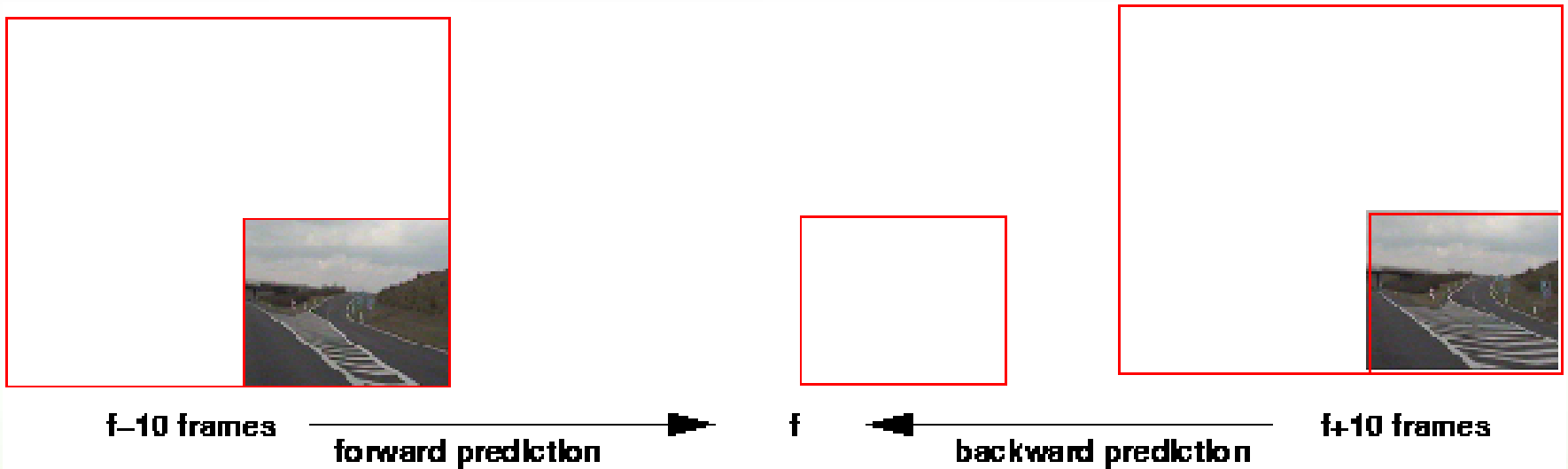

Different Frame Types

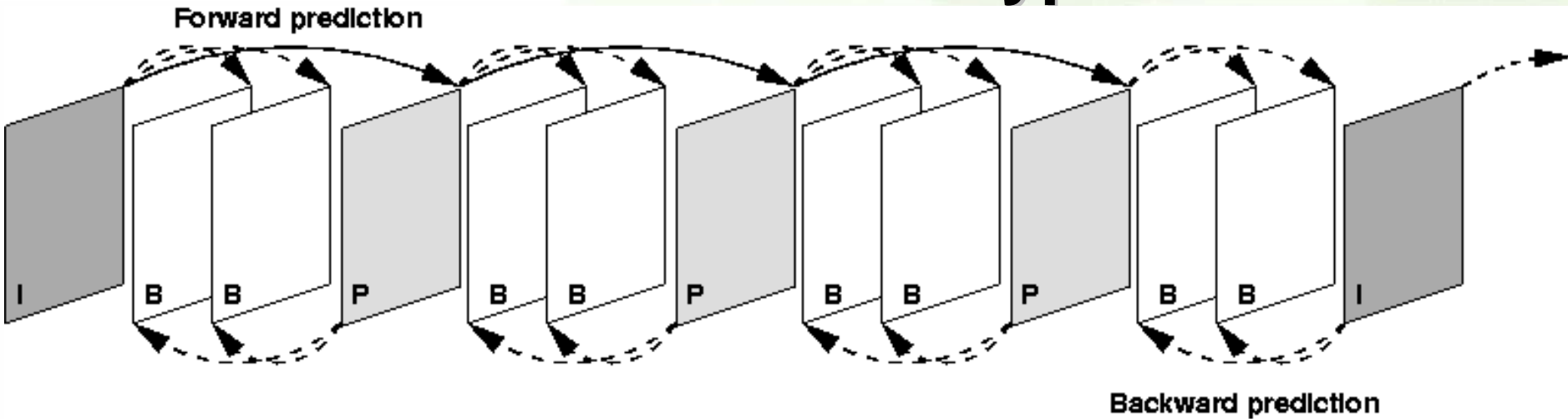

- I frames contain full picture information (intra coded)
- P frames contain differential information (uni directional predictive coding)
- B frames contain differential information (bi directional predictive coding)

Base Layer versus Enhancement Layer

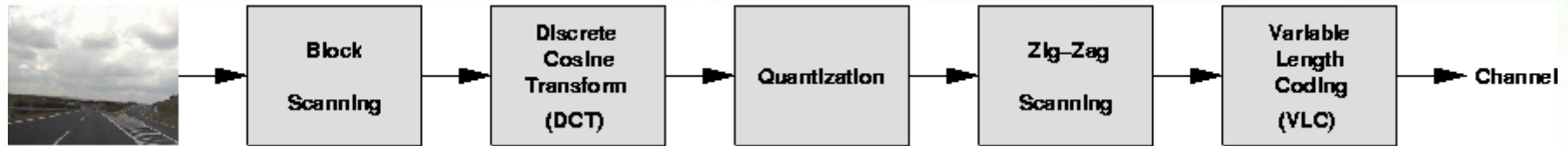

Base Layer

36	2	-2	1	0	0	0	0
8	-1	1	-1	0	0	0	0
-4	0	0	0	0	0	0	0
2	2	-1	1	0	0	0	0
0	-1	1	0	0	0	0	0
-1	0	0	0	0	0	0	0
1	1	0	0	0	0	0	0
-1	-1	0	0	0	0	0	0

Enhancement Layer

Temporal Scalability

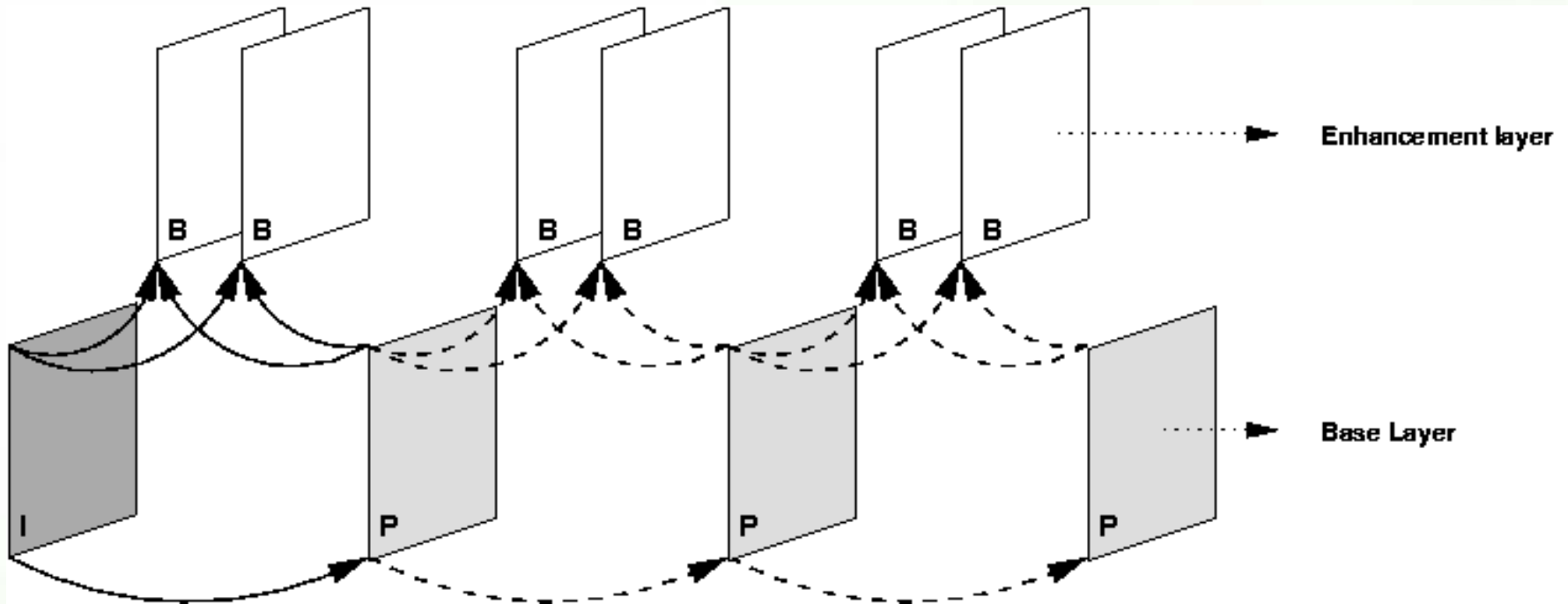

Spatial Scalability

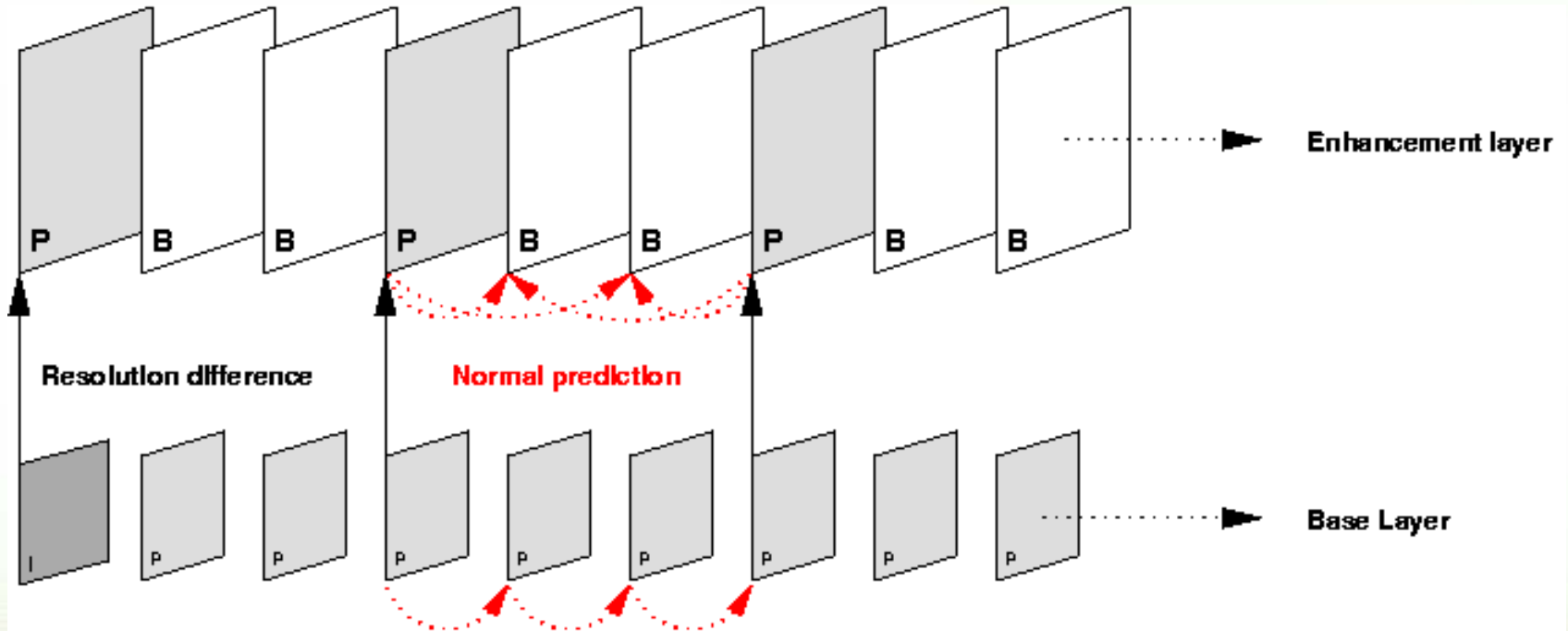

SNR Scalability

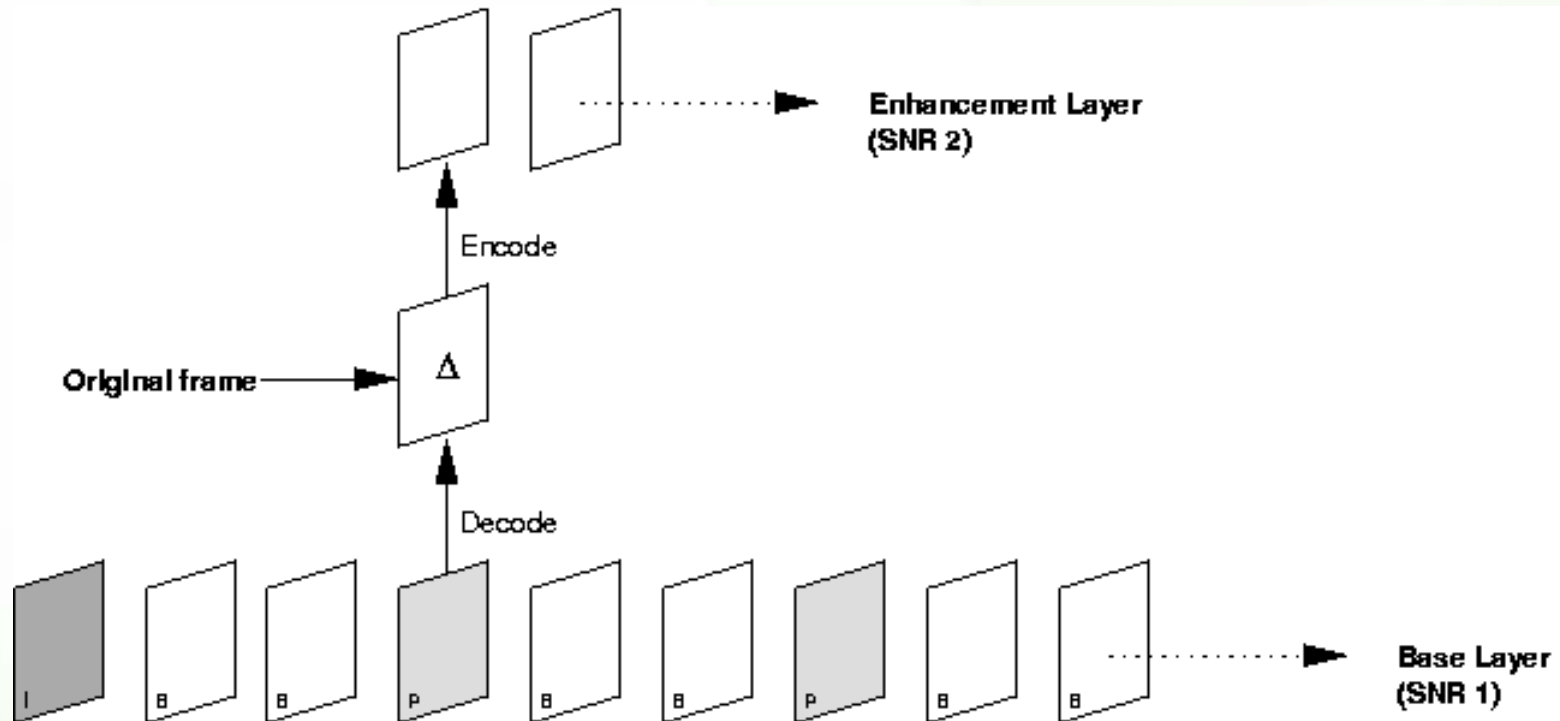

Object-based Scalability

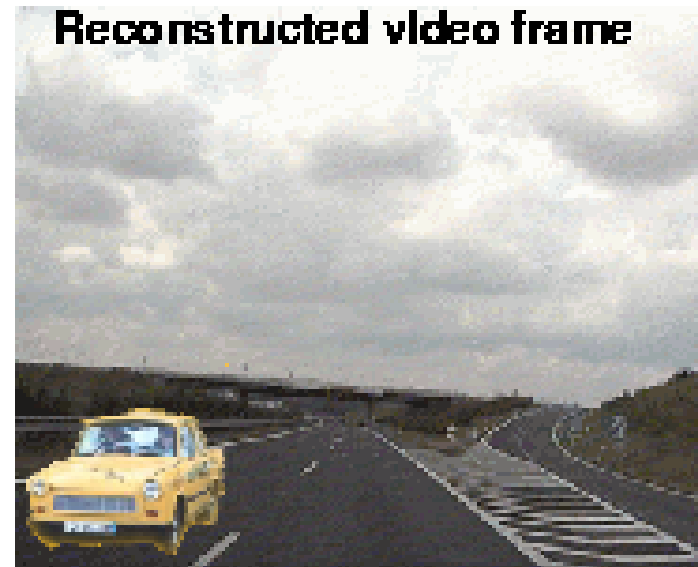
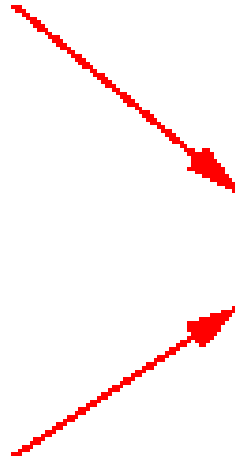

Video Codecs

» ISO/MPEG

- MPEG 1
- MPEG 2
- MPEG 4
- MPEG 7

» ITU-T

- H.261: $n \times 64$ kbit/
- H.263
- H.263+
- H.264 (H.26L or MPEG 4 Annex 10)

Video Codec

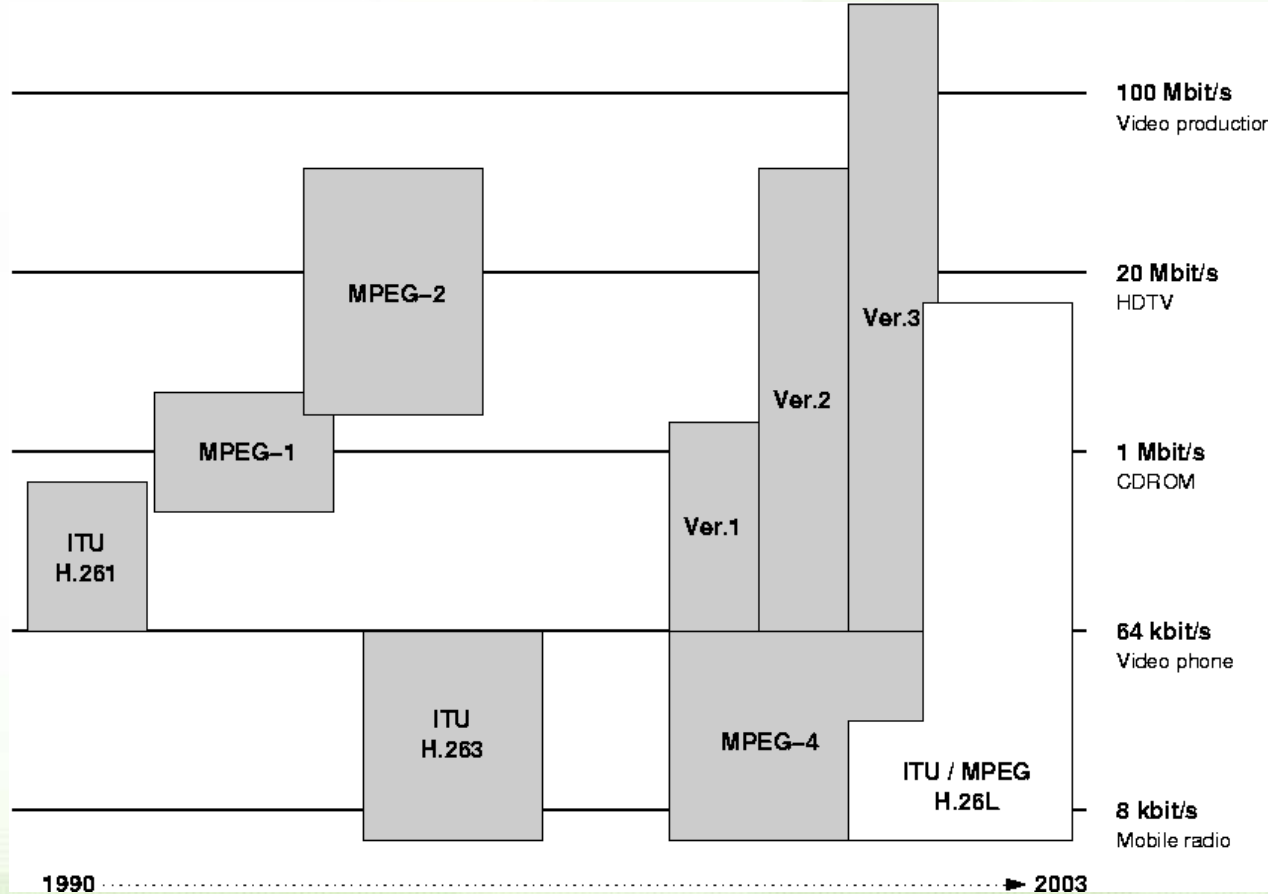

Milestones in Video Compression

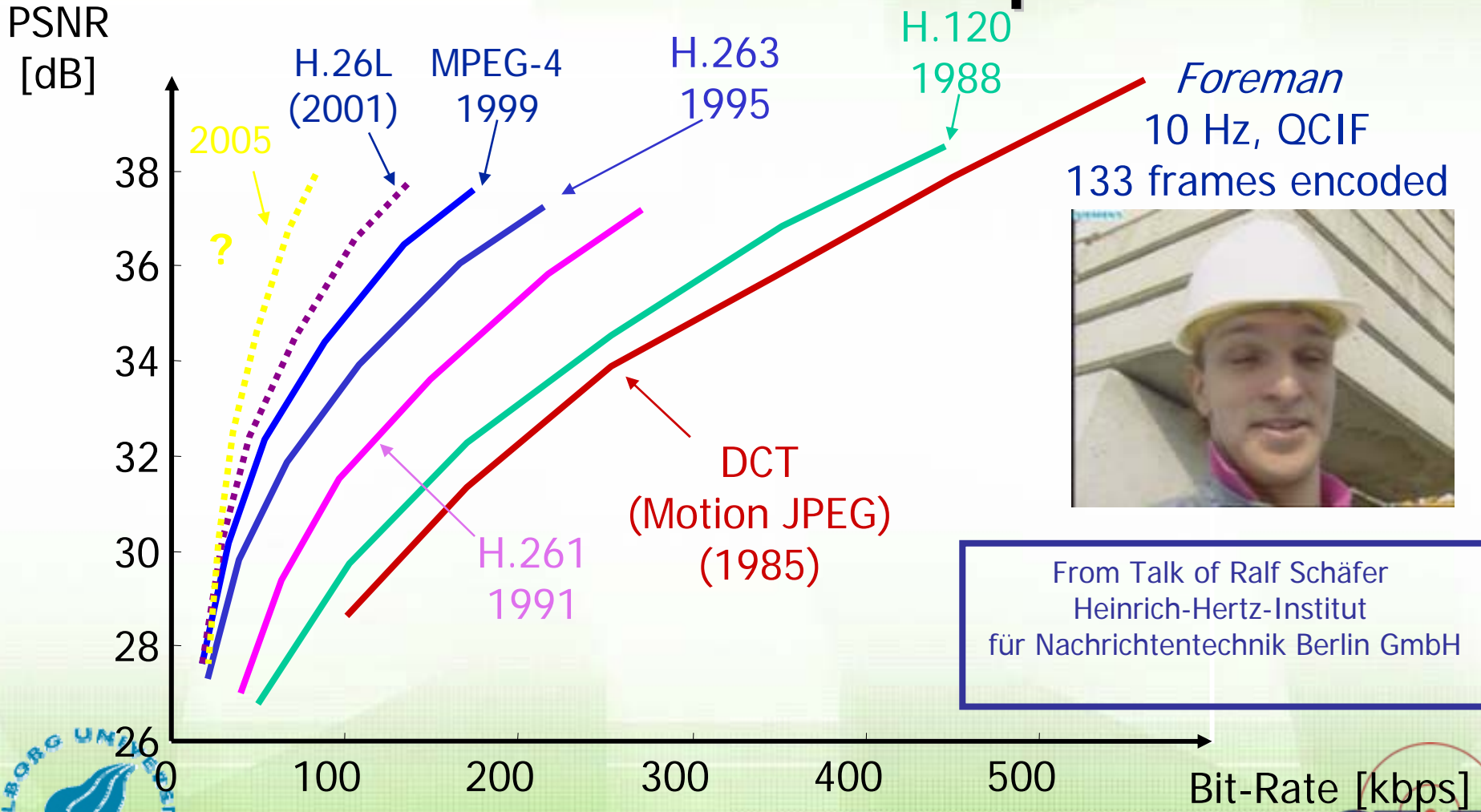

From Talk of Ralf Schäfer
Heinrich-Hertz-Institut
für Nachrichtentechnik Berlin GmbH

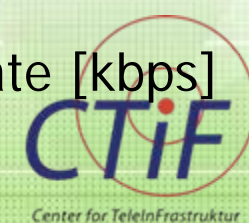

Bit Rate for Highway Video Sequence

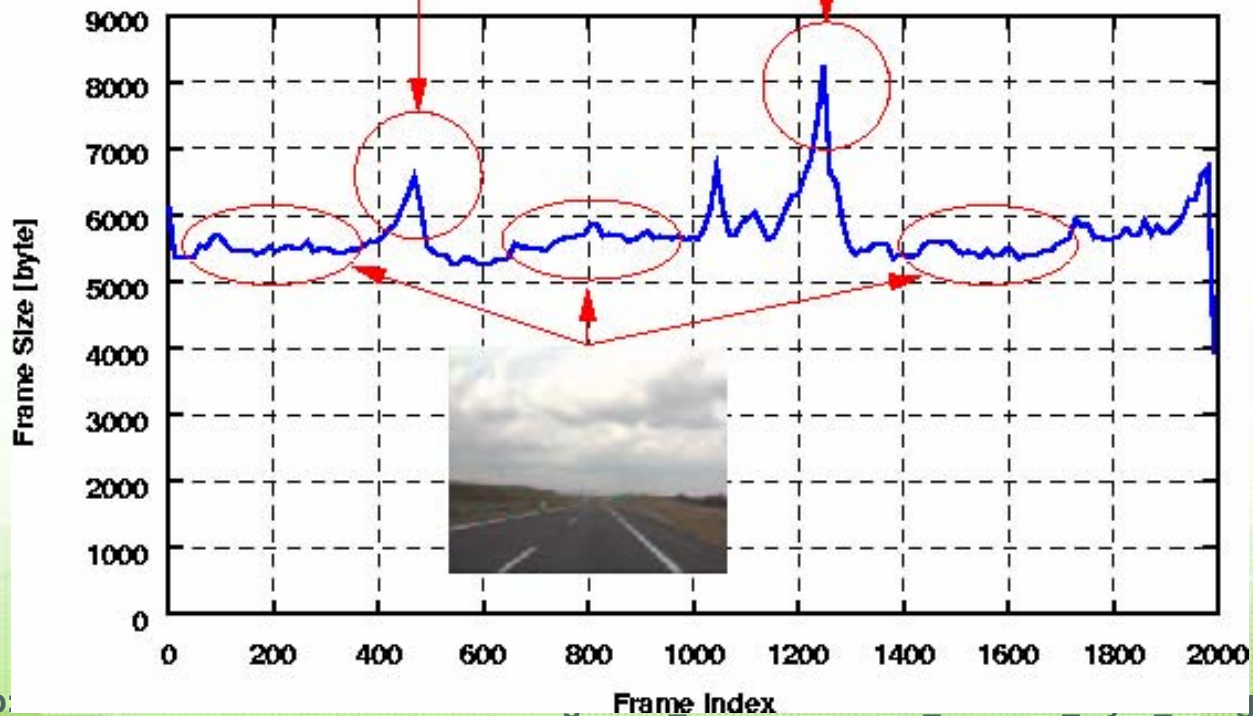

Frame Statistics for Starship Troopers



Frame statistics		
compression ratio	YUV:MP4	37.68
File Size	byte	9.1e+07
Video run time	msec	3.6e+06
# of Frames	-	89998
mean frame size	byte	1e+03
var frame size	-	6.5e+05
CoV of frame size	-	0.80
min frame size	byte	30
max frame size	byte	7265
Mean bit rate	bit/sec	2e+05
Peak bit rate	bit/sec	1.5e+06
Peak/Mean of bit rate	-	7.20

Data Rate over time for Starship

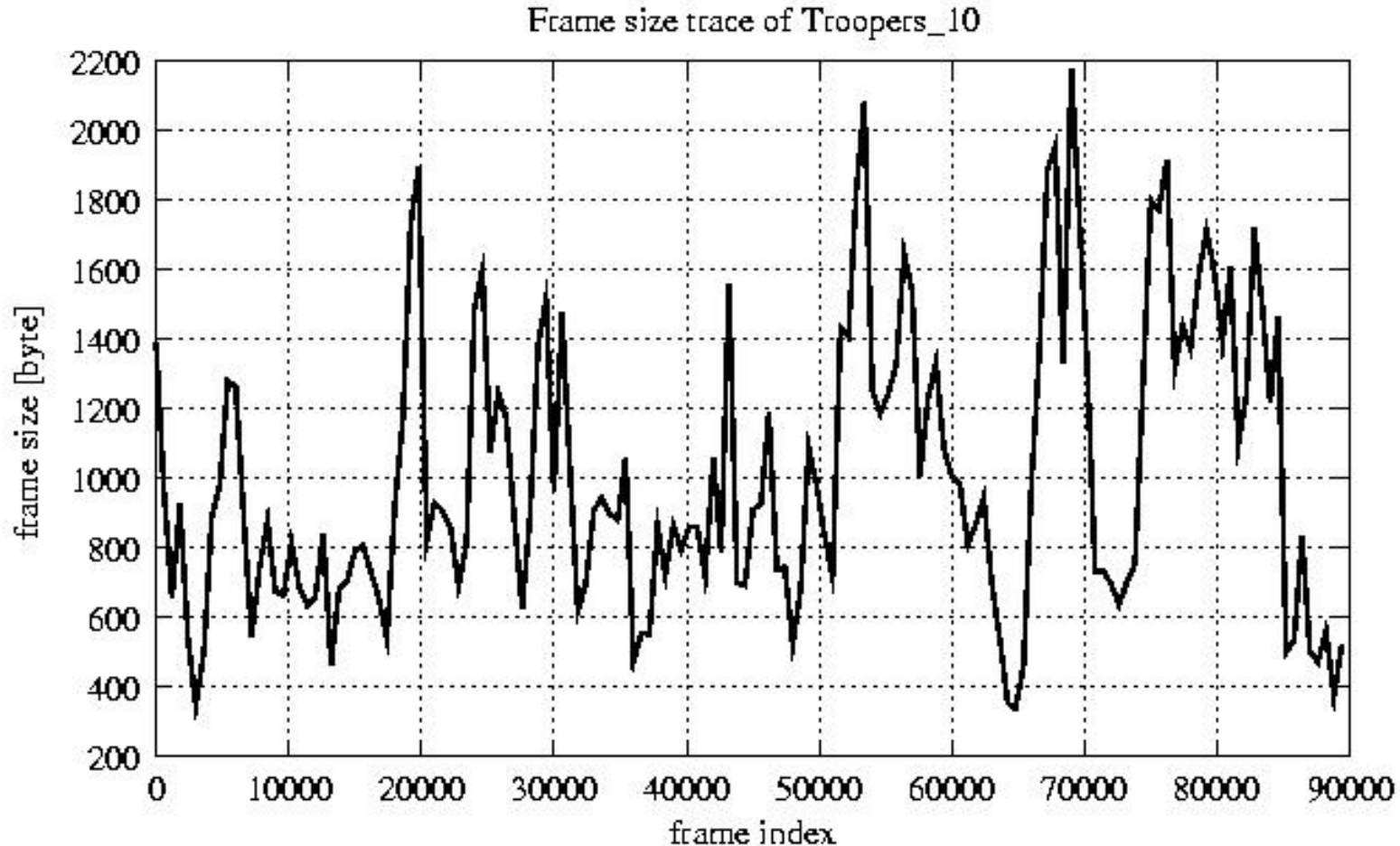

Frame Statistics for Ski (H.263)



		Frames, stuff	Rates	Frames, orig
compression ratio	YUV:H263	118.96		118.96
File size	byte	2.9e+07		2.9e+07
Video run time	msec	3.6e+06	3.6e+06	3.6e+06
# of Frames	-	90082.00		33121.00
mean frame size	byte	319.58		869.19
var frame size	-	214501.39		105675.74
CoV of frame size	-	1.45		0.37
min frame size	byte	0.00		51.00
max frame size	byte	5474.00		5474.00
Peak/Mean frame	-	17.13		6.30
Mean bit rate	bit/sec		6.4e+04	
Peak bit rate	bit/sec		3.6e+05	
Peak/Mean of bit rate	-		5.7	
CoV of bit rate	-		0.3	
max inter frame space	frames	1.00		<u>33.00</u>

Data Rate over time for Ski (H.263)

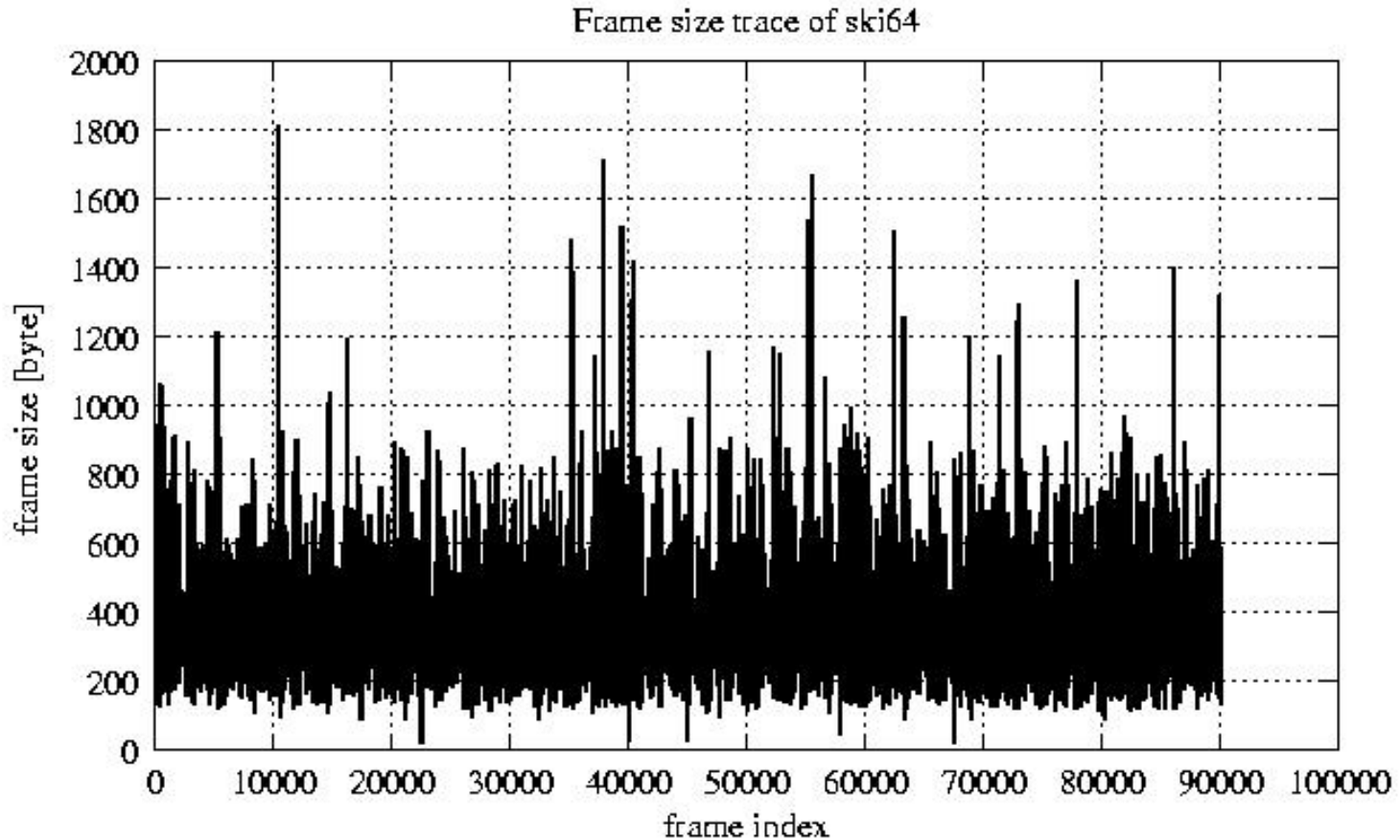

Multiple Description Coding

- » MDC codes data stream into independent descriptions (or sub-streams) any subset of which is decodable
- » At the receiver, these data streams are decoded individually and independently
- » The more the descriptors received the better the quality
- » Descriptors come at a higher price of overhead

MDC Streaming

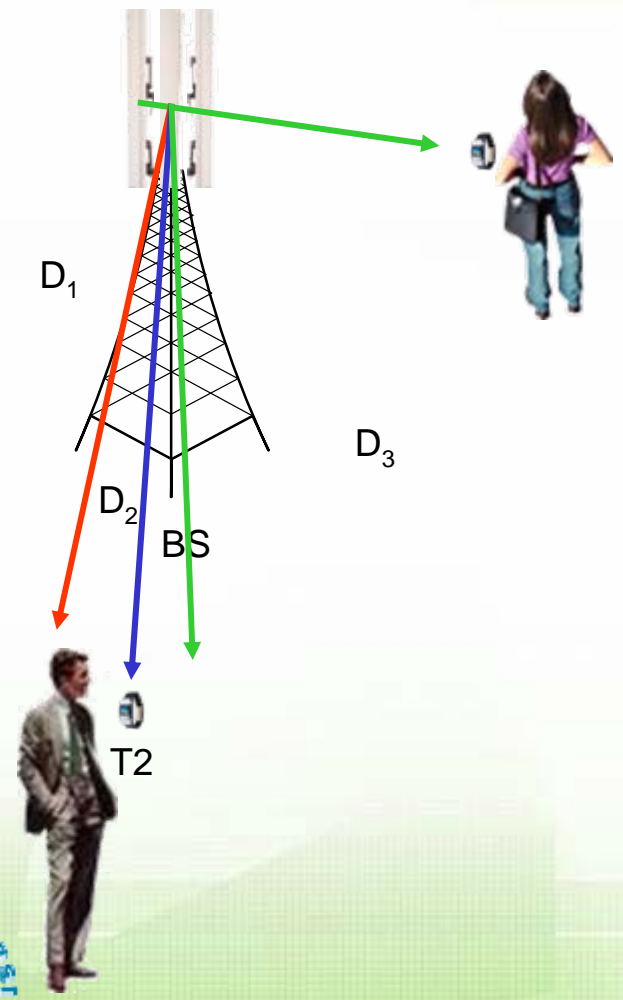

Methodology for MDC Measurement

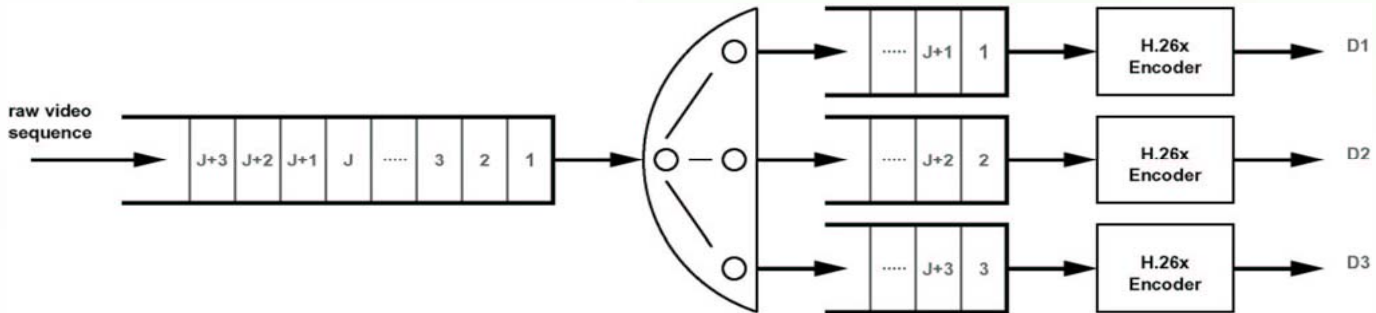

Splitter and encoding chain for MDC

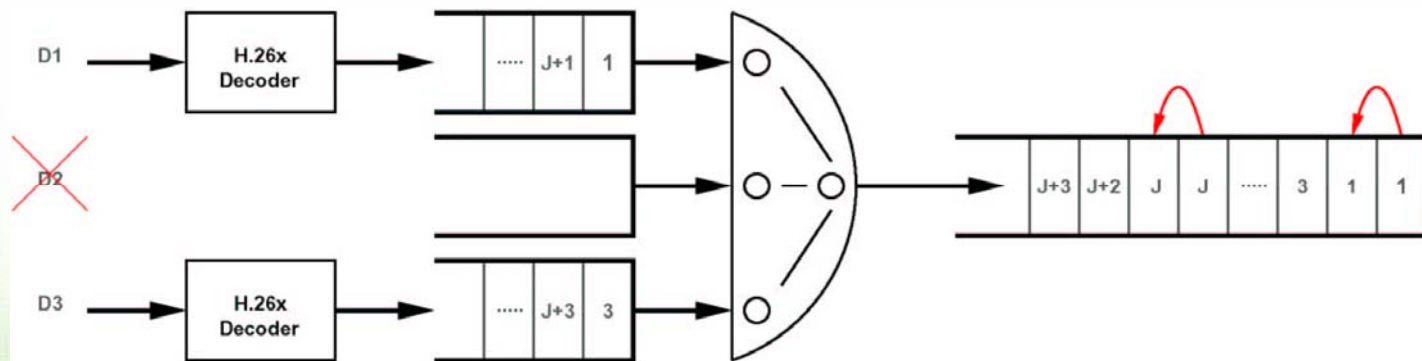

Merger and decoder chain for MDC

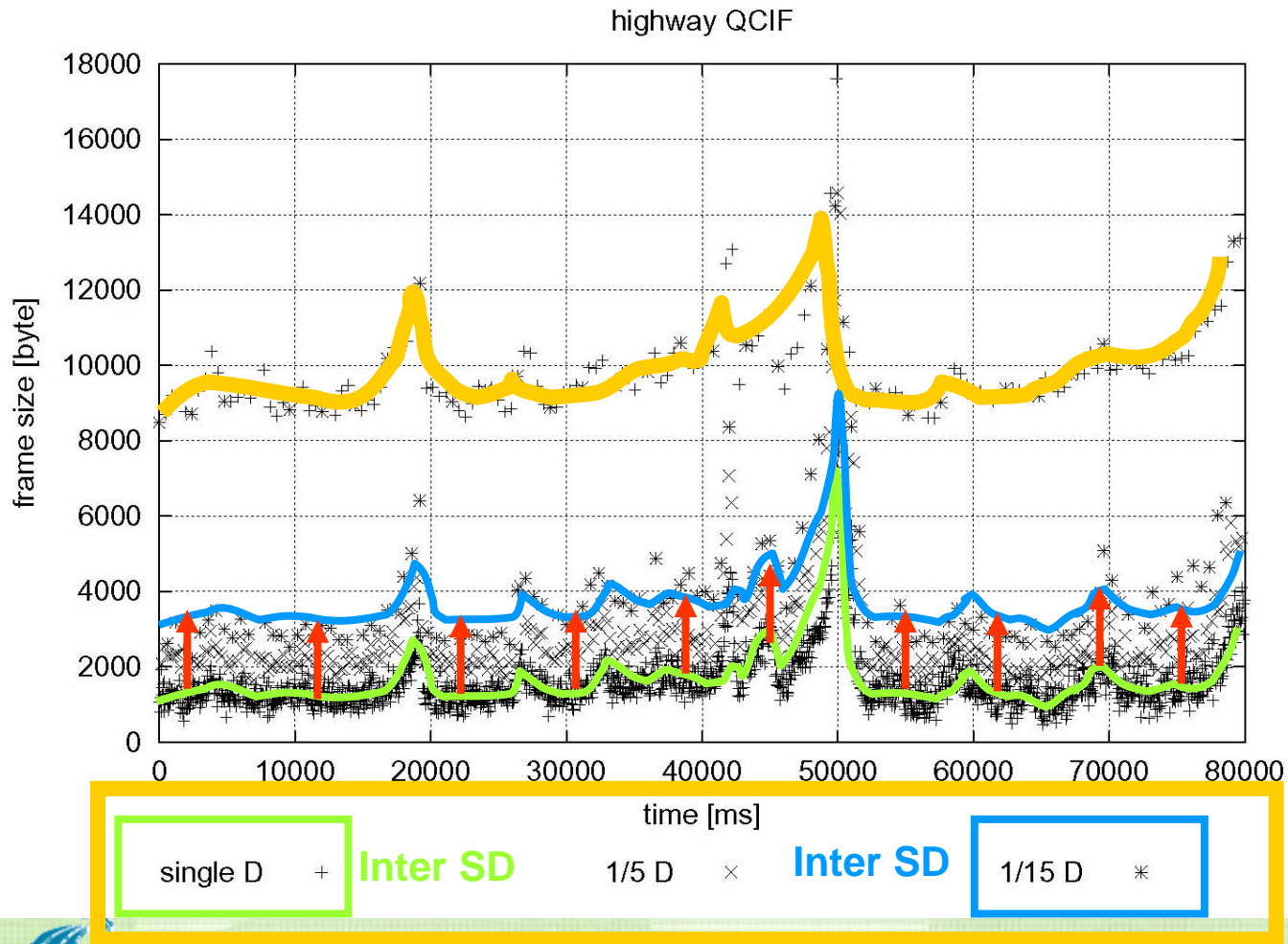

Overhead

Intra
Frame

Traffic Analysis for Multiple Description Coded Video Sequences - Mozilla

File Edit View Go Bookmarks Tools Window Help

Back Forward Reload Stop http://trace.kom.aau.dk/MDC/index.html Search Print

Home Bookmarks Google SPIEGEL AAUMail acticomMail MobPhones Cowinet LEO TV-Today

Multiple Description Video Trace Files and Statistics

[[Trace Website](#)] -> [[Video Traces](#)] -> [MDC Video Library]

On this page we present the traffic analysis for well known video sequences.

Click on one picture to get to the measurement results for this specific video sequence.

QCIF Video Sequences

start 3 Mozilla 4 Microsoft Powe... Adobe Acrobat - [C... 2 Windows Explorer EN 16:03



http://mobiledevices.kom.aau.dk/teaching/radio_communication_iii/cross_layer_design/



MDC Overhead (Network & Encoder) IPv4

- » MDC allows the splitting of video/audio/voice communication into autarky streams
- » Number of received streams is related to a given quality
- » Example: Quantization parameter refers to video quality (1 high 31 medium 51 low)

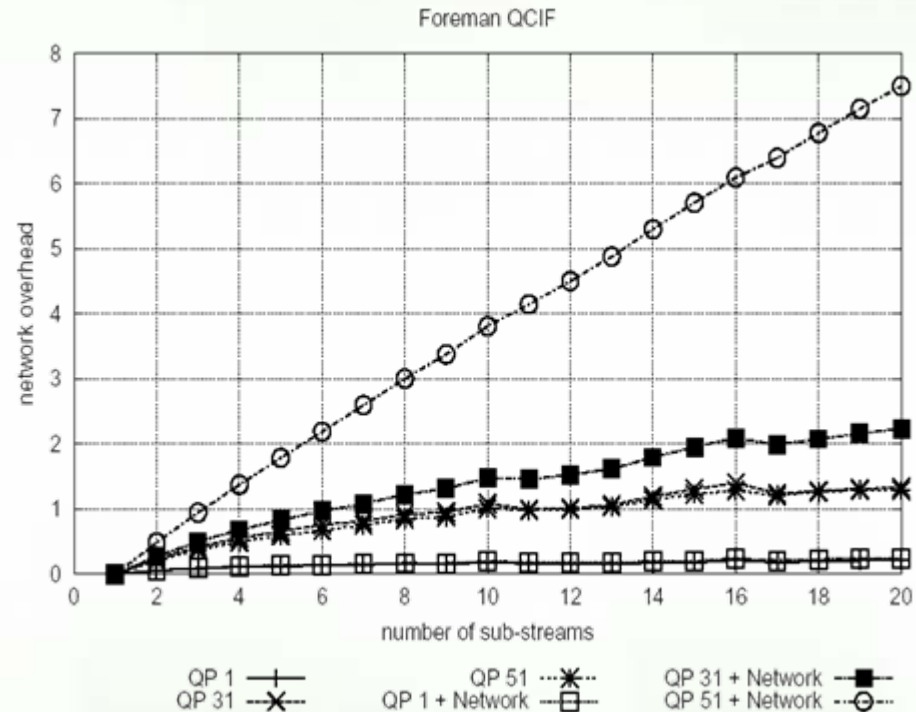

The network overhead for the foreman video sequence and three different quantization values (namely 1, 31, and 51) for IP version 4

Conclusion

trace.eas.asu.edu

trace.kom.aau.dk

MPEG4 and H.263 Video Trace Measurements

22 Movie/Sport/News

Statistics